



RAYCHEM C-WRAP SIDE ENTRY REPAIR SLEEVE

SELF-ADHESIVE FOR FAST, EASY, RELIABLE REPAIR
AND SEALING TO DAMAGED WIRE JACKETS

RAYCHEM C-WRAP SIDE ENTRY REPAIR SLEEVE

Rugged, Reliable, and Easy Wire Jacket Sealing and Repair



EASY INSTALLATION

- Easy to install: saves time, manpower, and cost
- Color-coded to ensure proper sizing for each application
- Low profile (small diameter and short length)
- Side entry for easy access to damaged wire

MECHANICALLY ROBUST

- 150 °C rated
- Long-term performance provides a permanent repair
- Wrap-around design eliminates de-pinning of connector for repair

Description

TE Connectivity's (TE) C-Wrap side repair sleeve is a side-entry sleeve designed to repair and seal a damaged wire jacket that is either chafed or has a radial crack or cut on the insulation. It consists of two pieces: the outer tubing and an adhesive inner layer.

MECHANICAL/ENVIRONMENTAL

- Environmental resistant
- Ideal for use on insulations rated at 135 °C or higher
- **Temperature range:** -65 °C to +150 °C

MATERIALS

- **Meltable Adhesive:** Modified thermoplastic fluoroelastomer
- **Insulation Sleeve:** Radiation cross-linked modified fluoropolymer

STANDARDS

- **SAE AS81824** (fluid and sealing requirements)
- **TE Performance Specification:** D-6201
- **TE Application Specification:** RPIP-1101
- **TE Qualification Test Reports:** ISTR-1134 and ISTR-1206

APPLICATION TOOLING

- **General Purpose Heat Gun:** Steinel HL1910E or HL2010E
- **SolderSleeve Reflector:** Steinel HL1802E-074616
- **Mil Spec installation tools:**
 - D-150-C-11: M81969/8-08
 - D-150-C-12: M81969/8-08
 - D-150-C-13: M81969/8-10
 - D-150-C-14: M81969/8-10

APPLICATIONS

- Used as a side-entry repair kit
- Repair of nicks, chafed and radial cracks on the wire in most Aerospace, Defense and Marine applications
- Prevents galvanic corrosion on center conductor
- RoHS compliant

TE Components . . . TE Technology . . . TE Know-how . . .

AMP | Agastat | CII | Hartman | Kilovac | Microdot | Nanonics | Raychem | Rochester | DEUTSCH

Get your product to market faster with a smarter, better solution.

ORDERING INFORMATION

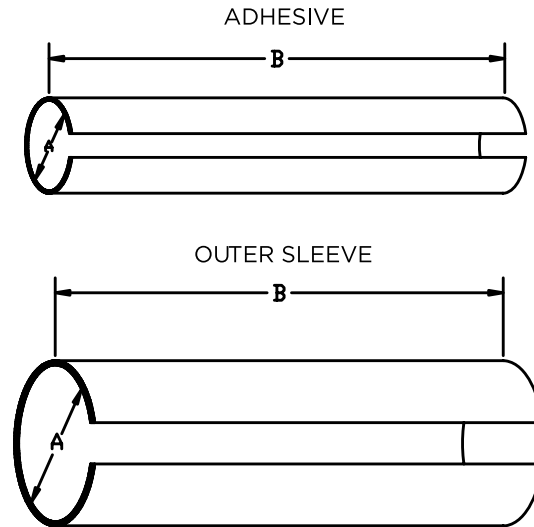

Part Description	Color Code	Product Dimension				Conductor	
		I.D. (A)		Cut Length (B)		AWG	Wire OD (Note*)
		Adhesive ±.05 (.002)	Sleeve ±.05 (.002)	Adhesive ±.5 (.02)	Sleeve ±.5 (.02)		
D-150-C-11	Green	1.11 (.044)	2.29 (.090)	21.59 (.85)	19.05 (.75)	26 - 24	0.80 - 1.10 (.031 - .043)
D-150-C-12	Red	1.68 (.066)	2.74 (.108)	21.59 (.85)	19.05 (.75)	22 - 20	1.10 - 1.50 (.043 - .029)
D-150-C-13	Blue	2.13 (.084)	3.43 (.135)	21.59 (.85)	19.05 (.75)	18 - 16	1.50 - 2.30 (.059 - .090)
D-150-C-14	Yellow	3.34 (.133)	4.80 (.189)	21.59 (.85)	19.05 (.75)	14 - 12	2.30 - 2.80 (.090 - .110)

MATERIALS

- **Meltable Adhesives:** Environment-resistant modified thermoplastic fluoroelastomer. Color coded.
- **Insulation Sleeve:** Heat-shrinkable, transparent, radiation cross-linked modified fluoropolymer. Color coded.

APPLICATION

- Parts are designed to provide an environment-resistant repair to damaged primary wire that has a radial crack up to 360°, nicks/scrapes not longer than 1/4" on insulations rated for 135°C minimum with no damage to the wire conductor. For insulation procedures, refer to RPIP 1101.

- Install using TE approved convection or infrared heating tools in accordance with TE. When installed with approved convection or infrared heating tools, assemblies will meet the performance requirements of TE D-6201 specification. Infrared tools are not recommended for use with black cable jackets.
- Temperature range: -65°C to +150°C.

Note*: If the O.D. of the wire is out of the range that is specified in the Table, use the next size of C-Wrap up or down



D-150-C-11
(Part No. CX2001-000)
NSN 5970-01-611-8609



D-150-C-12
(Part No. CX2096-000)
NSN 5970-01-611-8596



D-150-C-13
(Part No. CX2097-000)
NSN 5970-01-611-8600



D-150-C-14
(Part No. CX2098-000)
NSN 5970-01-611-8586

For More Information

TE Technical Support Center

North America	+1 800 522 6752
Asia Pacific	+86 0 400 820 6015
Austria	+43 1 905 601 228
Baltic Regions	+46 8 5072 5000
Benelux	+31 73 6246 999
Czech Republic	+420 800 701 462
France	+33 1 34 20 86 86
Germany	+49 6251 133 1999
Hungary	+36 809 874 04
Italy	+39 011 401 2632
Nordic	+46 8 5072 5000
Poland	+48 800 702 309
Russia	+7495 790 790 2
Spain/Portugal	+34 93 2910366
Switzerland	+41 52 633 66 26
United Kingdom	+44 800 267 666

Follow us on Twitter for all the latest product news
@TEConnectivity, and on Facebook, TEConnectivity.

te.com/c-wrap

© 2015 TE Connectivity Ltd. family of companies. All Rights Reserved.

4-1773463-8 ADM/RRD 1.5M 07/2015

Raychem, C-Wrap, SolderSleeve, TE Connectivity and the TE connectivity (logo) are trademarks of the TE Connectivity Ltd. family of companies.

Other product or company names mentioned herein may be trademarks of their respective owners.

While TE has made every reasonable effort to ensure the accuracy of the information herein, nothing herein constitutes any guarantee that such information is error-free, or any other representation, warranty or guarantee that the information is accurate, correct, reliable or current. The TE entity issuing this publication reserves the right to make any adjustments to the information contained herein at any time without notice. All implied warranties regarding the information contained herein, including, but not limited to, any implied warranties of merchantability or fitness for a particular purpose are expressly disclaimed. The dimensions herein are for reference purposes only and are subject to change without notice. Specifications are subject to change without notice.

Consult TE for the latest dimensions and design specifications.